

ERVS Single duct vav box in galvanised steel.



Description

These regulators are used to control and maintain the amount of air in VAV systems.

Notes

For correct pressure readings and for a flow rate tolerance of 5%, a straight duct with a length equal to 2/3 times the regulator diameter must be provided upstream. Otherwise, the air flow rate may vary between 10% and 20% from the calibrated value.

Characteristics

- Galvanised steel sheet casing;
- Dynamic Δp probe to measure and maintain the air flow rate according to the room demand;
- Galvanised steel damper with sealing gaskets;
- Operating range between 20 and 1500 Pa;
- Flow rate adjustment and control by means of a linearised motor controller;
- Self-generated and radiated noise tests according to the EN ISO 3741 Standard;
- Damper tightness test performed according to the EN 1751 Standard.
- VAV-COMPACT, AC/DC 24 V, MP-Bus, IP54 LMV-D3-M (5Nm) (Standard)

On demand

- VAV-Compact, AC/DC 24 V, Bacnet MS/TP, Modbus RTU, MP-Bus, IP54 LMV-D3-MOD (5Nm)
- VAV-Compact, AC/DC 24 V, KNX (S-Mode), IP54 LMV-D3-KNX (5Nm)

Models

- ERVS single casing.
- ERVS-I double casing.

Accessories

- Water or electric reheat coil (prices on request).

Simple casing diagram

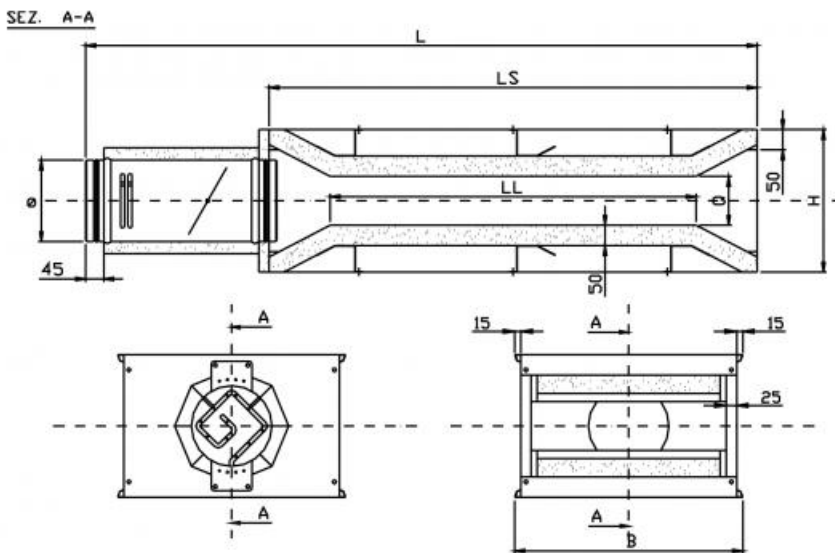

Simple casing dimensions

All dimensions are expressed in mm.

Ø	B	H	L	Q	LS	LL
125	380	270	1350	90	1000	800
160	380	270	1395	90	1000	800
200	560	360	1650	130	1200	900
250	560	360	1720	130	1200	900
315	780	460	2010	180	1400	1000
355	780	460	2065	180	1400	1000
400	980	510	2230	230	1500	1100

Double casing diagram

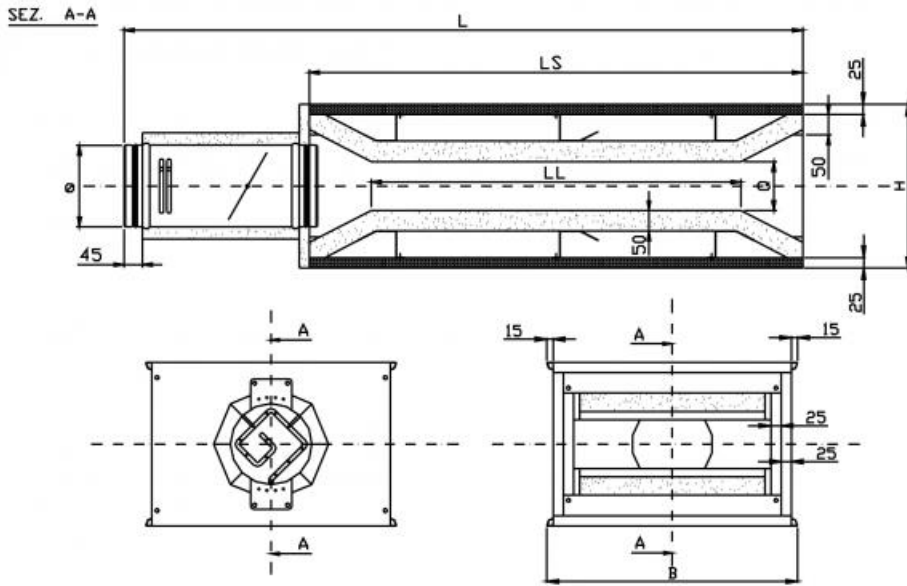

Double casing dimensions

Ø	B	H	L	Q	LS	LL
125	430	320	1350	90	1000	800
160	430	320	1395	90	1000	800
200	610	410	1650	130	1200	900
250	610	410	1720	130	1200	900
315	830	510	2010	180	1400	1000
355	830	510	2065	180	1400	1000
400	1030	560	2230	230	1500	1100

Coil for variable flow rate units

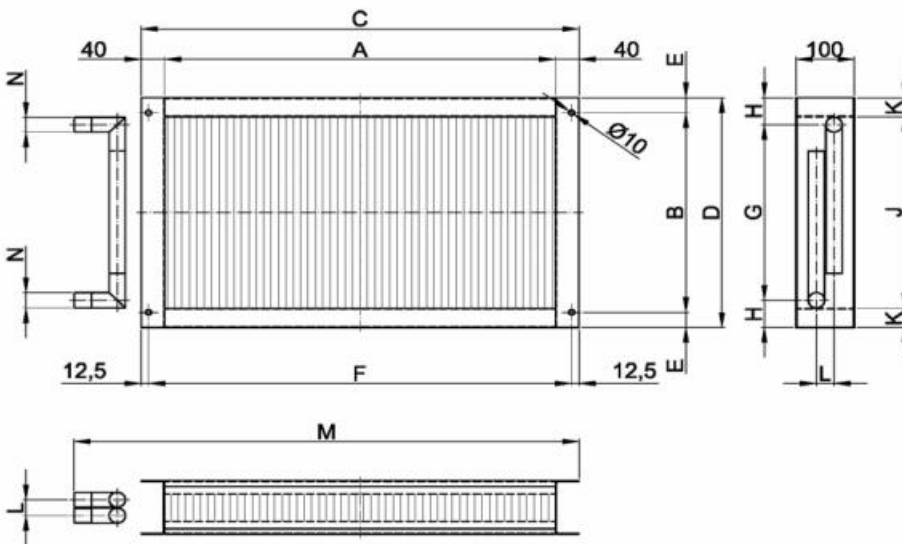

ERVS size	Number of rows	A	B	C	D	E	F	G	H	J	K	L	M	N
125	1	270	175	350	257	41	325	150	53,5	180	38,5	0	386	1/2"
125	2	270	175	350	257	41	325	150	53,5	180	38,5	26	386	1/2"
160	1	270	175	350	257	41	325	150	53,5	180	38,5	0	386	1/2"
160	2	270	175	350	257	41	325	150	53,5	180	38,5	26	386	1/2"
200	1	450	275	530	332	28,5	505	240	46	240	46	26	605	1/2"
200	2	450	275	530	332	28,5	505	240	46	240	46	26	605	1/2"
250	1	450	275	530	332	28,5	505	240	46	240	46	26	605	1/2"
250	2	450	275	530	332	28,5	505	240	46	240	46	26	605	1/2"
315	1	670	375	750	432	28,5	725	338	47	360	36	25	855	1/2"
315	2	670	375	750	432	28,5	725	330	51	360	36	30	865	3/4"
355	1	670	375	750	432	28,5	725	338	47	360	36	25	855	1/2"
355	2	670	375	750	432	28,5	725	330	51	360	36	30	865	3/4"
400	1	870	425	950	482	28,5	925	362	60	390	46	30	1065	3/4"
400	2	870	425	950	482	28,5	925	362	60	390	46	30	1065	3/4"
500	1	870	525	950	600	37,5	925	482	59	510	45	30	1065	3/4"
500	2	870	525	950	600	37,5	925	475	62,5	510	45	38	1070	1"
630	1	1070	655	1150	720	32,5	1125	595	63	630	45	38	1270	1"
630	2	1070	655	1150	720	32,5	1125	588	66	630	45	45	1280	1 1/4"

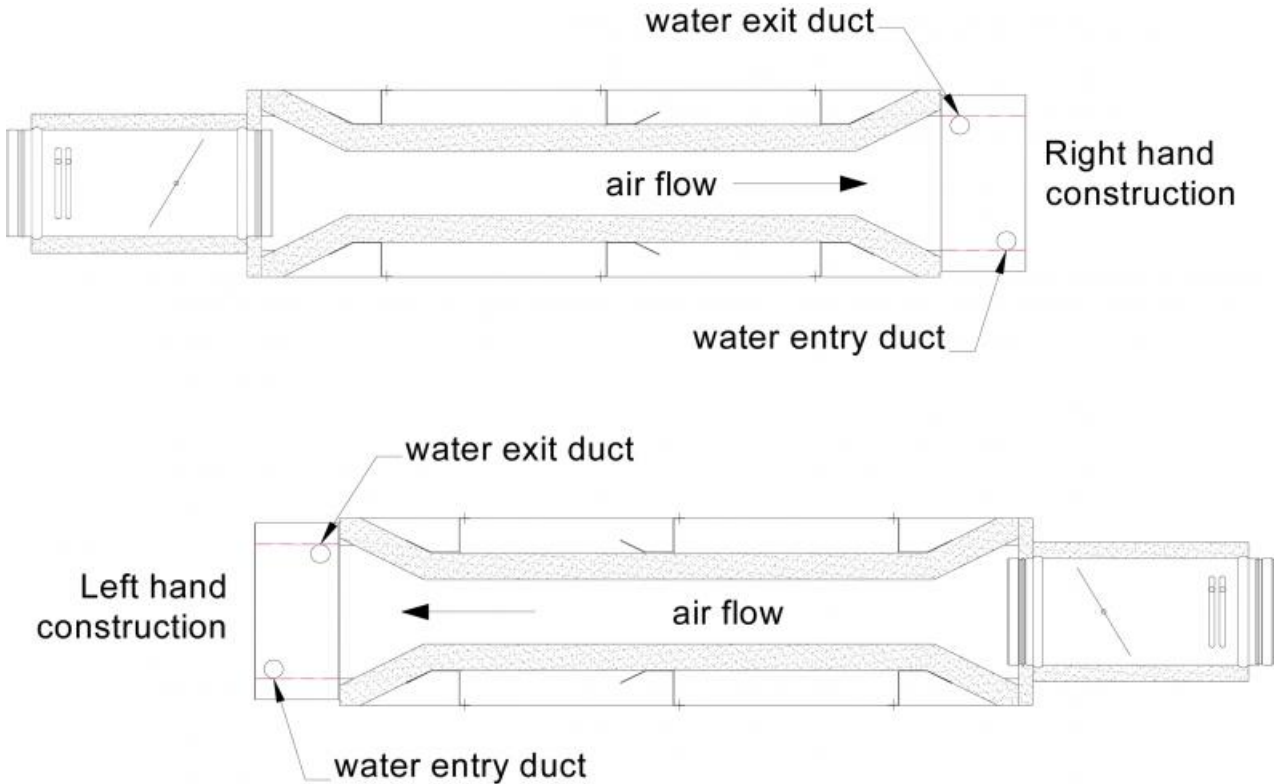

Operating data and price list

When ordering, indicate the minimum and maximum air flow rates to be programmed.

Prices and characteristics of water coils on request.

Model	Minimum air flow rate m ³ /h	Maximum air flow rate m ³ /h	ERVS single casing, Control signal	ERVS single casing, Control signal	ERVS-I double casing, Control signal	ERVS-I double casing, Control signal
			2...10V euro	0...10V euro	2...10V euro	0...10V euro
125	53	445	829,71 ∨	829,71 ∨	1093,39 ∨	1093,39 ∨
160	87	725	841,38 ∨	841,38 ∨	1167,93 ∨	1167,93 ∨
200	138	1130	1012,46 ∨	1012,46 ∨	1457,43 ∨	1457,43 ∨
250	212	1770	1029,59 ∨	1029,59 ∨	1525,42 ∨	1525,42 ∨
315	337	2810	1266,46 ∨	1266,46 ∨	1900,45 ∨	1900,45 ∨
355	428	3570	1290,47 ∨	1290,47 ∨	1953,46 ∨	1953,46 ∨
400	543	4525	1504,64 ∨	1504,64 ∨	2293,61 ∨	2293,61 ∨