

EVHRD EC Recuperator with dehumidification and air treatment from 300 to 500 m³/h with compressor and inverter



Description

The EVHRD EC is a controlled mechanical ventilation unit with heat recuperator and high efficiency inverter compressor, air treatment section with dehumidification, cooling and heating integration. The unit is equipped with plug-and-play solution for quick and simplified installation. The unit consists of a monoblock inclusive of each component for the proper operation and allows the operation with wide temperature range.

Characteristics

Perimeter structure self-supporting in galvanized sheet.
Panels are made from double sandwich panel, with extrernhally painted finish.
The insulation panel is made with high-performance insulation 23 mm thickness.
Polypropylene exchanger in countercurrent high efficiency exceeding 90%. Summer and winter operation.
Fans plug-fun brushless electronic motor and modulating control. High efficiency and low noise levels. Comply with Directive Erp.
ePM1 filter easily removable on external air inlet and outlet on the air. Coarse filters with low pressure drop and easily removable on the air recirculation .
Electrical panel on the unit with microprocessor and dedicated control.
Refrigeration circuit with high efficiency inverter compressor.

Command electronics

Version K:
Electrical panel on board unit with microprocessor and dedicated regulation. Fan management, display of internal machine temperature probes, timed dirty filter management, recirculation and renewal air management. Possibility to control the unit with these three solutions:
1-Management through external commands and 0-10vdc signal to control air flow from minimum to maximum;
2-Management through remote panel with integrated T / H sensor
3-MODBUS RTU RS 485 communication

Use

The unit is particularly suitable for residential, commercial or collective residential buildings where, in addition to the air exchange, it is necessary to dehumidify the presence of radiant systems.

Version

Version DC: version for dehumidification and integration in cooling / heating.

Unit for the renewal of the ambient air with the external one through a high efficiency recuperator, the air flow is increased by partially recirculating the ambient air thus allowing to dehumidify the air and to provide an integration of the cooling / thermal power radiant air conditioning system.

During the summer (active compressor) the unit can work in 2 modes:

Renewal + Dehumidification: The unit condenses partially in air and partially in water through the plate condenser, obtaining dehumidified air;

Renewal + Dehumidification + Cooling integration: The unit completely condenses in water, thus obtaining dehumidified and cooled air. During the winter period (compressor off) the hydronic battery is supplied with hot water from the heating system and behaves like a thermo-ventilator with recuperator.

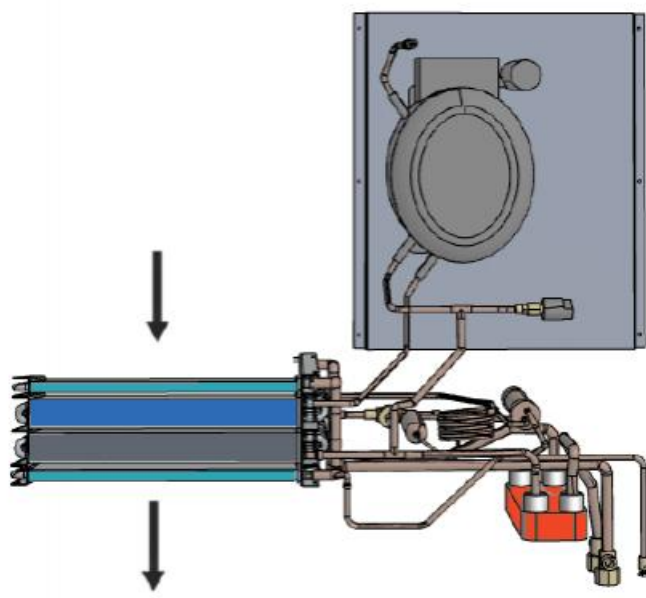

Operation only with ventilation

The EVHRD unit will cater for mechanical ventilation with high efficiency heat recovery. It will be possible to select the fan speeds in order to obtain the desired flow rate to meet the air renewal requirements.

The selectable flow rates are:

On size EVHRD EC 30-15 from 0 to 150 m³/h

On size EVHRD EC 50-25 from 0 to 250 m³/h

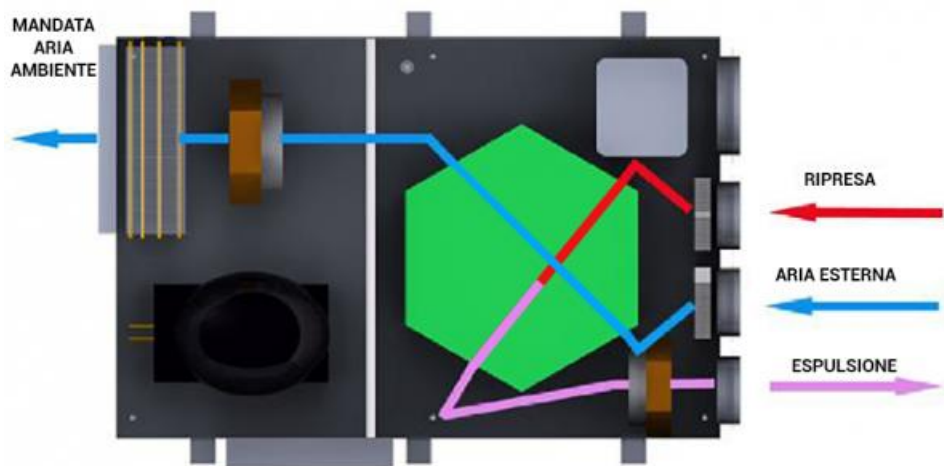

Ventilation, dehumidification and integration operation

The EVHRD EC unit will continue to satisfy mechanical ventilation with high efficiency heat recovery but will increase the air flow, recirculating from a dedicated room air duct to increase the air volume on the integration part. The integration part consists of a version with dehumidification and integration and hydronic integrative batteries.

It finds its most common application in radiant systems where there is a need for dehumidification and the integration of cooling in the summer period. During operation, the unit uses humidity and temperature probes to activate the refrigeration circuit composed of the compressor, the air evaporation coil and the air and water condenser powered by the radiant system, thus realizing the dehumidification of the air and the integration of cooling. In the winter period, it is however possible to use the unit to integrate the radiant heating by feeding the hydronic hot water battery, obtaining a rapid heat input to the room.

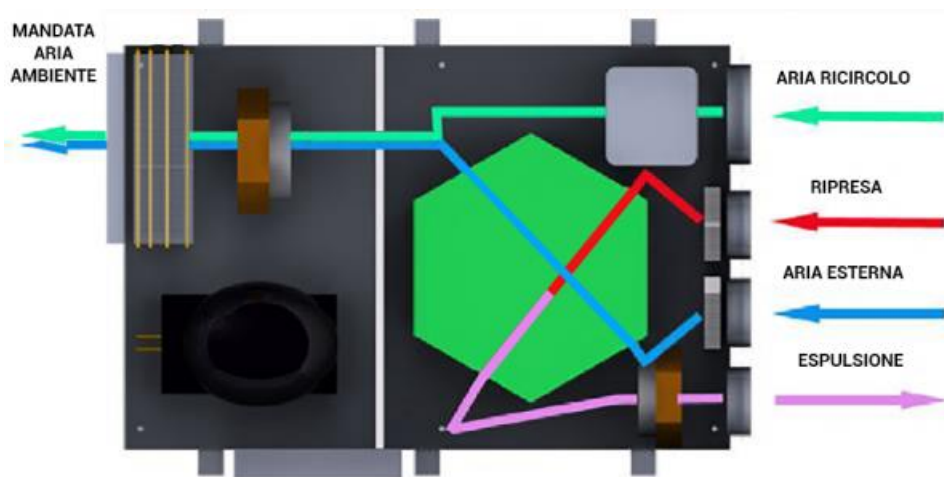

Unit performance - General data

(1) Temperatura aria esterna 7°; umidità relativa 72%. temperatura ambiente 20°C; umidità relativa 28%, portata aria nominale

Grandezza EVHRD EC		Versione ORIZZONTALE		Versione VERTICALE	
		30/15	50/25	30/15	50/25
Efficienza nominale invernale recuperatore (1)	%	85,7	86	83,9	86
Portata aria esterna nominale	m³/h	154	265	161	258
Portata aria totale	m³/h	297	520	302	538
classificazione dei vari modelli secondo il regolamento europeo 1253/2014 e 1254/2014		B	A	B	A

Technical features

- (1) External air temperature 33°; relative humidity 50%. room temperature 25°C; relative humidity 50%, water temperature 16°. nominal air and water flow
- (2) External air temperature 33°; relative humidity 50%. room temperature 25°C; relative humidity 50%, water temperature 16°. nominal air and water flow
- (3) Ambient temperature 20°C; relative humidity 50%, nominal air flow; Water at 35°C

EVHRD EC		ORIZZONTALE		VERTICALE	
		30/15	50/25	30/15	50/25
Capacità di deumidificazione utile (al netto del contenuto entalpico dell'aria esterna) (1)	l/24h	75	99	75	99
Potenza frigorifera totale (2)	kW	3,3	4,35	3,3	4,35
Potenza assorbita compressore	kW	0,88	1,06	0,88	1,06
Frequenza compressore	Hz	68	80	68	80
EER		3,71	4,1	3,71	4,1
Potenza frigorifera sensibile (disponibile sono in fase di integrazione)	kW	1,4	1,91	1,4	1,91
Potenza termica resa (3)	kW	0,7	1,25	0,7	1,25
Portata acqua	m ³ /h	0,15	0,2	0,15	0,2
Perdita di carico	Kpa	12	9	12	9
Pressione sonora Lp ad 3 Mt	dB(A)	41,6	42,9	41,0	41,4
	V/Ph/Hz	230/1/50		230/1/50	
Corrente massima assorbita in funzionamento	A	4,7	5,9	4,7	5,9
Potenza massima assorbita in funzionamento	kW	1,02	1,27	1,02	1,27
Corrente massima assorbita componenti	A	7,5	8,1	7,5	8,1
Potenza massima assorbita componenti	kW	1,61	1,73	1,61	1,73

Dimensions horizontal versions:

DIMENSIONI EVHRD EC		Versione ORIZZONTALE	
		30/15	50/25
Larghezza A	mm	1220	1220
Profondità B	mm	820	960
Altezza C	mm	255	330
Ingresso aria di ricircolo DN1	mm	160	200
Ingresso aria viziata DN2	mm	125	160
Ingresso aria di rinnovo DN3	mm	125	160
Espulsione aria viziata DN4	mm	125	160
Mandata GxH	mm	347x177	518x252
Attacchi acqua mandata/ritorno	Ø	1/2"-1/2"	1/2"-1/2"
Diametro scarico condensa	Ø	20	20

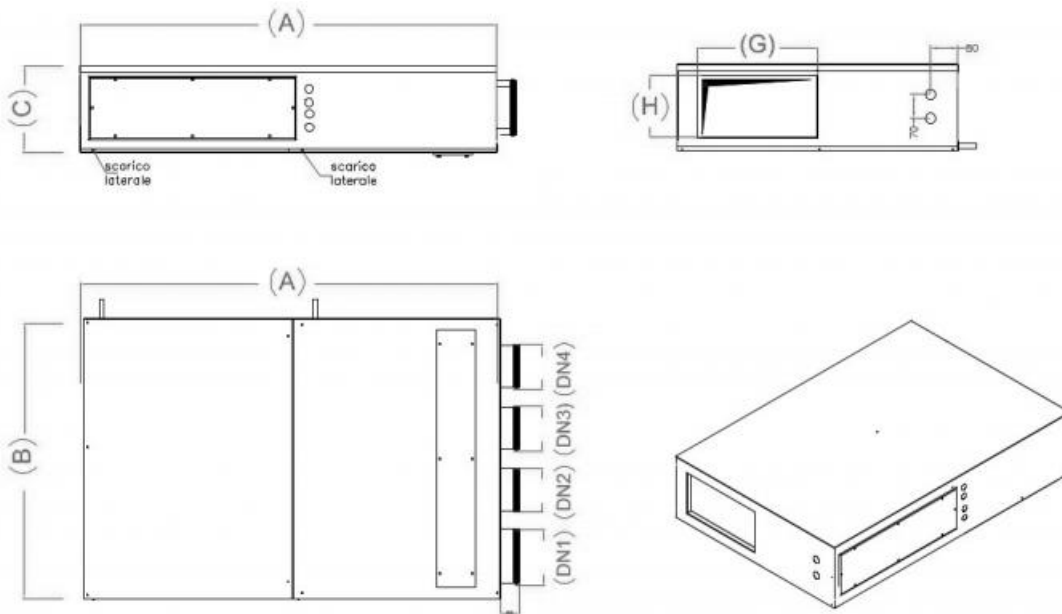

Dimensions vertical versions:

DIMENSIONI EVHRD EC		Versione VERTICALE	
		EVHRD 30/15	EVHRD 50/25
Larghezza L	mm	885	985
Profondità W	mm	515	740
Altezza H	mm	1085	1185
Ingresso aria di ricircolo DN1	mm	160	200
Ingresso aria viziata DN2	mm	125	160
Ingresso aria di rinnovo DN3	mm	125	160
Espulsione aria viziata DN4	mm	125	160
Mandata	mm	347x177	518x252
Attacchi acqua mandata/ritorno	Ø	1/2"-1/2"	1/2"-1/2"
Diametro scarico condensa	Ø	20	20

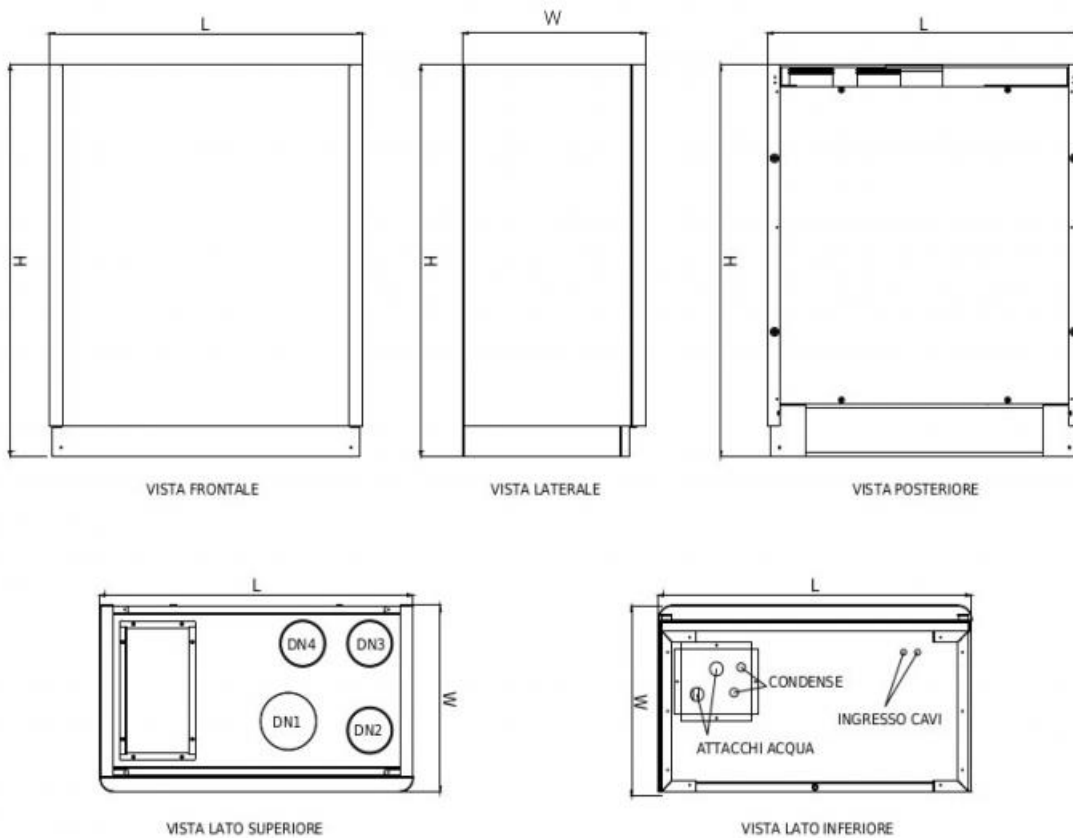

Price recovery and accessories VERSION K

Item normally available from stock								
	modello	euro	accessori					
			controllo elettronico remoto	controllo elettronico remoto	Valvola acqua on/off a 2 vie 1/2"	Valvola acqua on/off a 3 vie 1/2"	kit filtri	EDRM Serranda di modulazione presa aria esterna
			EVCNU	EVCNU-2				
			euro	euro	euro	euro	euro	
ORIZZONTALE	EVHRD EC 30/15	▼	▼	▼	▼	▼	▼	▼
	EVHRD EC 50/25	▼	▼	▼	▼	▼	▼	▼
VERTICALE	EVHRD EC 30/15	▼	▼	▼	▼	▼	▼	▼
	EVHRD EC 50/25	▼	▼	▼	▼	▼	▼	▼



Listino plenum di mandata isolato

All dimensions are expressed in mm.

Item normally available from stock							
Configurazione	Modello	L	H	P	Ø	euro	
Orizzontale	EVHRD EC 30/15	347	177	100	1x160	▼	
	EVHRD EC 50/25	518	252	100	2x160	▼	
Verticale	EVHRD EC 30/15	347	177	100	1x160	▼	
	EVHRD EC 50/25	518	252	100	2x160	▼	

