



Description

The EVHRD is a unit of controlled mechanical ventilation with heat recovery unit high efficiency, air treatment section with dehumidification, cooling and heating. The unit is equipped with plug-and-play solution for quick and simplified installation. The unit consists of a monoblock inclusive of each component for the proper operation and allows the operation with wide temperature range.

Characteristics

Perimeter structure self-supporting in galvanized sheet.

Panels are made from double sandwich panel, with extrernhally painted finish.

The insulation panel is made with high-performance insulation 23 mm thickness.

Polypropylene exchanger in countercurrent high efficiency exceeding 90%. Summer and winter operation.

Fans plug -fun brushless electronic motor and modulating control. High efficiency and low noise levels. Comply with Directive Erp.

ePM1 filter easily removable on external air inlet and outlet on the air. Coarse filters with low pressure drop and easily removable on the air recirculation.

Electrical panel on the unit with microprocessor and dedicated control.

Cooling circuit with high efficiency compressor

Command electronics

Version K:

Electrical panel on board unit with microprocessor and dedicated regulation. Fan management, display of internal machine temperature probes, timed dirty filter management, recirculation and renewal air management. Possibility to control the unit with these three solutions:

1-Management through external commands and 0-10vdc signal to control air flow from minimum to maximum;

2-Management through remote panel with integrated T / H sensor

3-MODBUS RTU RS 485 communication

Use

The unit is particularly suitable for residential, commercial or collective residential buildings where, in addition to the air exchange, it is necessary to dehumidify the presence of radiant systems.

Versions

Version D: version for dehumidification with neutral air (isothermal).

Unit for the renewal of the ambient air with the external one through a high efficiency recuperator, the air flow is increased by partially recirculating the ambient air thus allowing the operation of the refrigeration circuit, obtaining during the summer period (compressor active) dehumidified air.

Equipped with a post-cooling / heating hydronic battery which, if supplied, provides a supplement to the cooling / heating capacity of the radiant air-conditioning system (the connection to the heating / cooling system is optional and does not affect air dehumidification).

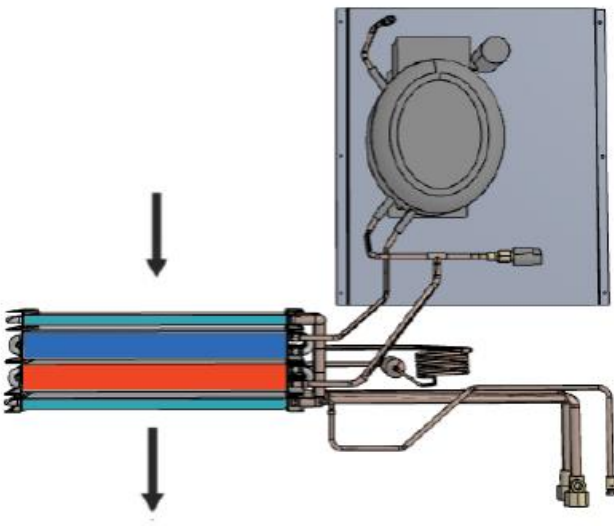

Version DC: version for dehumidification and integration in cooling / heating.

Unit for the renewal of the ambient air with the external one through a high efficiency recuperator, the air flow is increased by partially recirculating the ambient air thus allowing to dehumidify the air and to provide an integration of the cooling / thermal power radiant air conditioning system.

During the summer (active compressor) the unit can work in 2 modes:

Renewal + Dehumidification: The unit condenses partially in air and partially in water through the plate condenser, obtaining dehumidified air;

Renewal + Dehumidification + Cooling integration: The unit completely condenses in water, thus obtaining dehumidified and cooled air. During the winter period (compressor off) the hydronic battery is supplied with hot water from the heating system and behaves like a thermo-ventilator with recuperator.

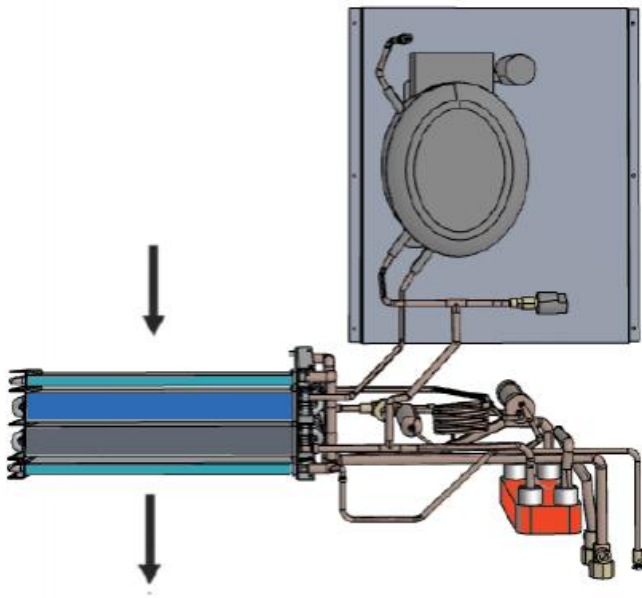

Operation only with ventilation

The EVHRD unit will cater for mechanical ventilation with high efficiency heat recovery. It will be possible to select the fan speeds in order to obtain the desired flow rate to meet the air renewal requirements.

The selectable flow rates are:

On size EVHRD 30-15 from 0 to 150 m³/h

On size EVHRD 50-25 from 0 to 250 m³/h

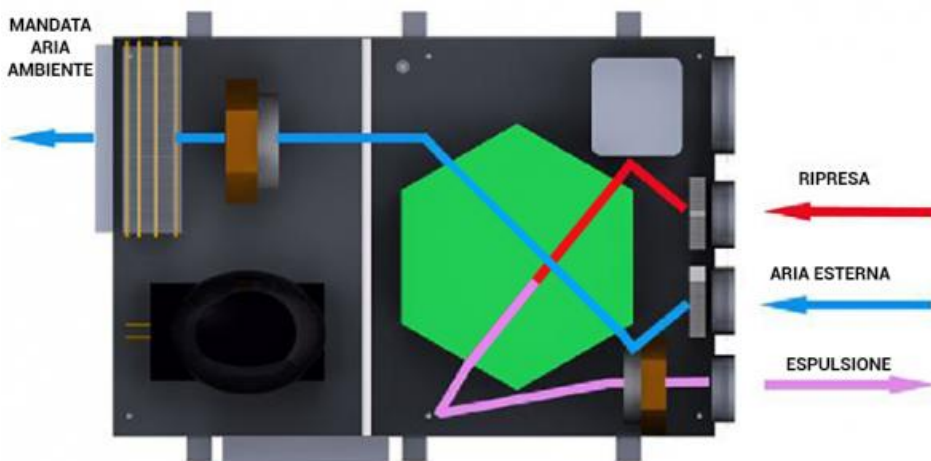

Ventilation, dehumidification and integration operation

The EVHRD unit will continue to satisfy the mechanical ventilation with high efficiency heat recovery but will increase the air flow rate, recirculating from a dedicated ambient air duct to increase the air volume on the integration part.

The integration part can consist of a version

with dehumidification (Version D), from a version with dehumidification and integration (Version DC) and hydronic supplementary batteries.

The D version, finds its most common application, in radiant systems where there is the need of only dehumidification in the summer. During operation, the unit, through humidity and temperature probes, activates the refrigerant circuit composed of the compressor, the air evaporation coil and the air condenser, thus performing dehumidification. It is possible to supply the hydronic post battery with the radiant system water (the lack of battery power does not compromise the operation of the refrigeration circuit) it is possible to integrate it with the summer cooling and the winter heating.

The DC version, finds its most common application, in radiant systems where there is the need for dehumidification and the integration of cooling in the summer. During operation, the unit, through humidity and temperature probes, activates the refrigerant circuit composed of the compressor, the air evaporation coil and the air and water condenser supplied by the radiant system, thus achieving air dehumidification and integration. cooling.

In winter, it is still possible to use the unit to integrate the radiant heating by feeding the hot water hydronic battery, obtaining a rapid thermal contribution to the environment.

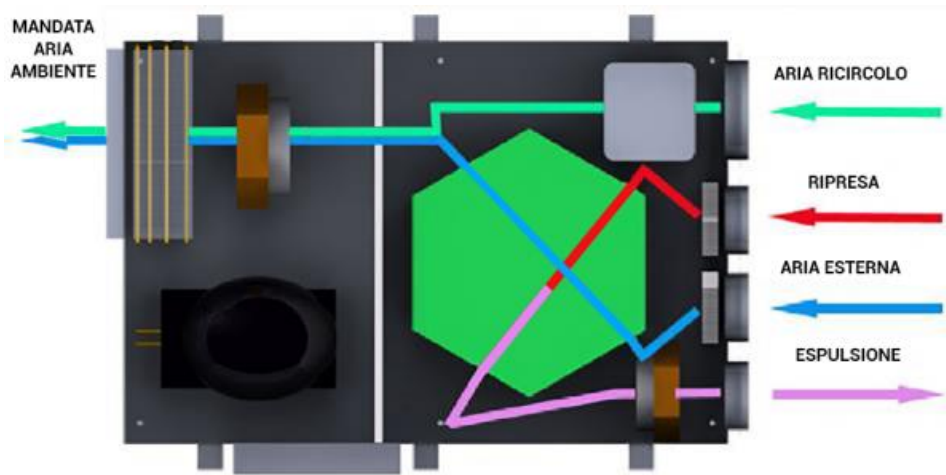

Unit performance - General data

(1) Temperatura aria esterna 7°; umidità relativa 72%. temperatura ambiente 20°C; umidità relativa 28%, portata aria nominale

Grandezza		Versione ORIZZONTALE		Versione VERTICALE	
		EVHRD 30/15	EVHRD 50/25	EVHRD 30/15	EVHRD 50/25
Efficienza nominale invernale recuperatore (1)	%	85,7	86	83,9	86
Portata aria esterna nominale	m³/h	154	265	161	258
Portata aria totale	m³/h	297	520	302	538
classificazione dei vari modelli secondo il regolamento europeo 1253/2014 e 1254/2014		B	A	B	A

(1) Temperatura aria esterna 30°; umidità relativa 60%. temperatura ambiente 25°C; umidità relativa 50%, portata aria nominale

(2) Temperatura ambiente 25°C; umidità relativa 60%, portata aria nominale; Acqua in 16°C Acqua out 18°C

(3) Temperatura ambiente 20°C; umidità relativa 60%, portata aria nominale; Acqua in 35°C Acqua out 30°C.

VERSIONE D		Versione ORIZZONTALE		Versione VERTICALE	
		EVHRD 30/15	EVHRD 50/25	EVHRD 30/15	EVHRD 50/25
Capacità di deumidificazione utile (al netto del contenuto entalpico dell'aria esterna) (1)	l/24h	30,5	56	30,5	56
Potenza frigorifera resa batteria idronica (2)	kW	0,7	1,56	0,7	1,56
Portata acqua	m³/h	0,25	0,35	0,25	0,35
Perdita di carico	Kpa	8,5	10,5	8,5	10,5
Potenza termica resa (3)	kW	0,86	1,4	0,86	1,4
Pressione sonora Lp ad 3 Mt	dB(A)	40,8	40,9	40,8	40,9
Alimentazione	V/Ph/Hz	230 / 1 / 50			
Corrente massima assorbita	A	5,5	7	5,5	7

(1) Temperatura aria esterna 30°; umidità relativa 60%. temperatura ambiente 25°C; umidità relativa 50%, portata aria nominale

(2) Temperatura ambiente 25°C; umidità relativa 60%, portata aria nominale; Acqua in 16°C Acqua out 18°C

(3) Temperatura ambiente 20°C; umidità relativa 60%, portata aria nominale; Acqua in 35°C Acqua out 30°C.

VERSIONE DC		Versione ORIZZONTALE		Versione VERTICALE	
		EVHRD 30/15	EVHRD 50/25	EVHRD 30/15	EVHRD 50/25
Capacità di deumidificazione utile (al netto del contenuto entalpico dell'aria esterna) (1)	l/24h	30,5	56	30,5	56
Potenza frigorifera resa compressore (2)	kW	1,55	2,4	1,55	2,4
Potenza frigorifera resa batteria idronica (2)	kW	0,7	1,56	0,7	1,56
Portata acqua	m³/h	0,25	0,35	0,25	0,35
Perdita di carico	Kpa	8,5	10,5	8,5	10,5
Potenza termica resa (3)	kW	0,86	1,4	0,86	1,4
Pressione sonora Lp ad 3 Mt	dB(A)	40,8	40,9	40,8	40,9
Alimentazione	V/Ph/Hz	230 / 1 / 50			
Corrente massima assorbita	A	5,5	7	5,5	7

Dimensions orizzontal versions:

DIMENSIONI		Versione ORIZZONTALE	
		EVHRD 30/15	EVHRD 50/25
Larghezza A	mm	1220	1220
Profondità B	mm	820	960
Altezza C	mm	255	330
Ingresso aria di ricircolo DN1	mm	160	200
Ingresso aria viziata DN2	mm	125	160
Ingresso aria di rinnovo DN3	mm	125	160
Espulsione aria viziata DN4	mm	125	160
Mandata GxH	mm	347x177	518x252
Attacchi acqua mandata/ritorno	Ø	1/2"-1/2"	1/2"-1/2"
Diametro scarico condensa	Ø	20	20

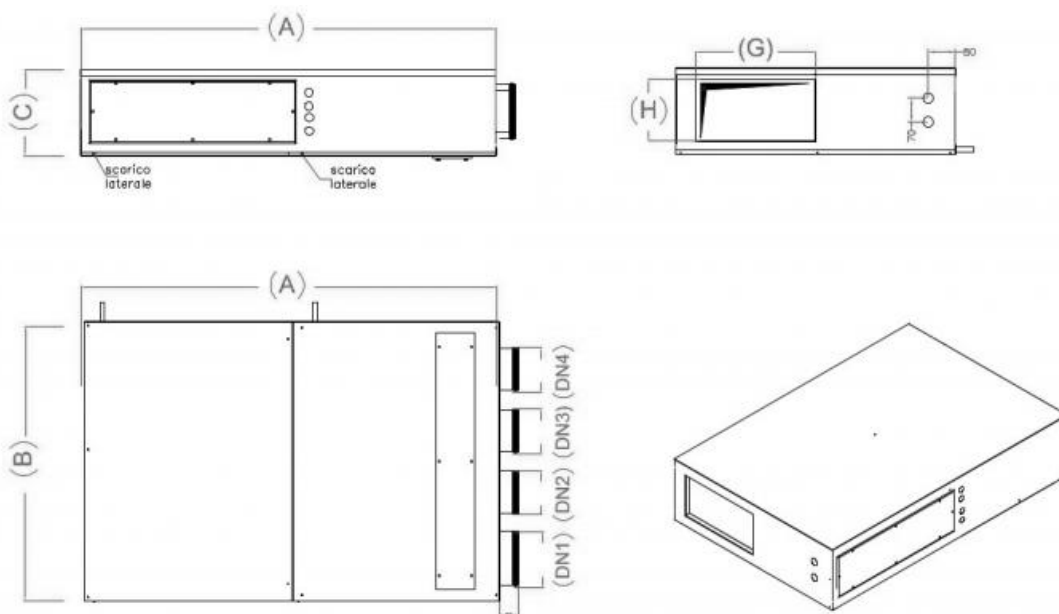

Dimensions vertical versions:

DIMENSIONI		Versione VERTICALE	
		EVHRD 30/15	EVHRD 50/25
Larghezza L	mm	885	985
Profondità W	mm	515	740
Altezza H	mm	1085	1185
Ingresso aria di ricircolo DN1	mm	160	200
Ingresso aria Viziata DN2	mm	125	160
Ingresso aria di rinnovo DN3	mm	125	160
Espulsione aria viziata DN4	mm	125	160
Mandata	mm	347x177	518x252
Attacchi acqua mandata/ritorno	Ø	1/2"-1/2"	1/2"-1/2"
Diametro scarico condensa	Ø	20	20

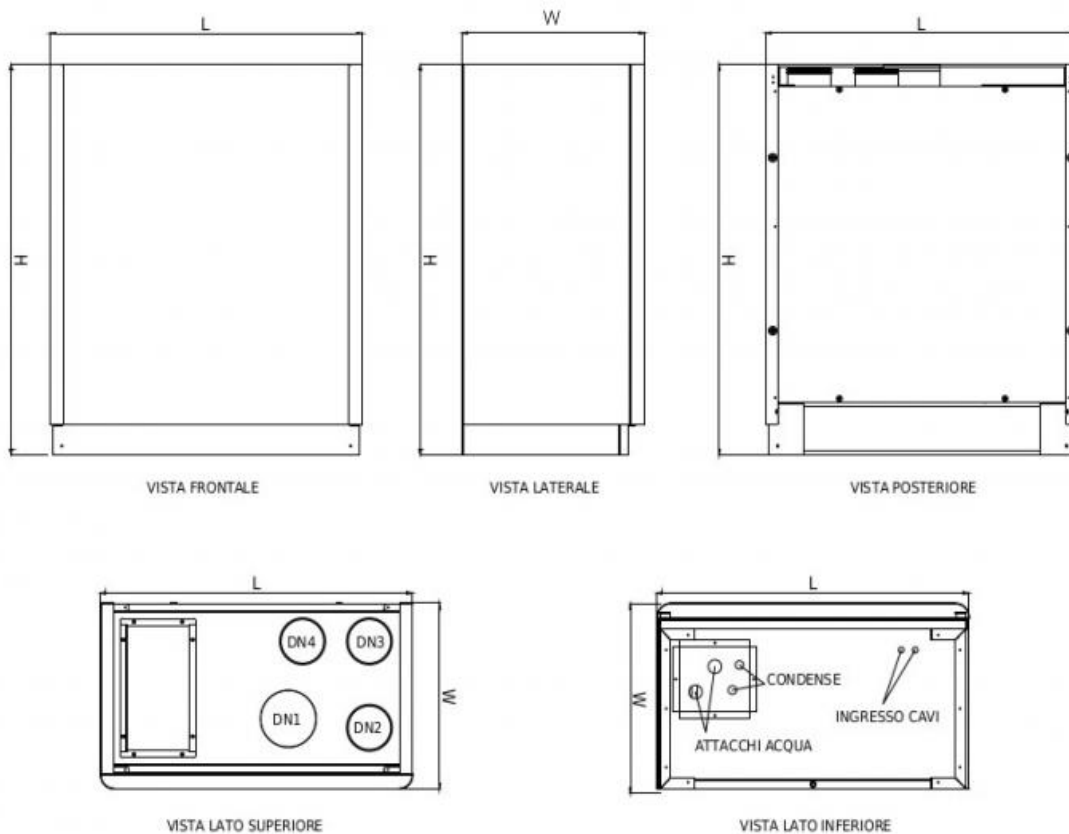

Price recovery and accessories VERSION K

Item normally available from stock

	modello	versione del recuperatore		accessori				
		D	DC	controllo elettronico remoto		Valvola acqua on/off a 2 vie 1/2"	Valvola acqua on/off a 3 vie 1/2"	kit filtri
		euro	euro	EVCNU	EVCNU-2			
				euro	euro	euro	euro	euro
ORIZZONTALE	EVHRD 30/15	▼	▼	▼	▼	▼	▼	▼
	EVHRD 50/25	▼	▼	▼	▼	▼	▼	▼
VERTICALE	EVHRD 30/15	▼	▼	▼	▼	▼	▼	▼
	EVHRD 50/25	▼	▼	▼	▼	▼	▼	▼



Listino plenum di mandata isolato

All dimensions are expressed in mm.

Item normally available from stock						
Configurazione	Modello	L	H	P	Ø	euro
Orizzontale	EVHRD 30/15	347	177	100	1x160	▼
	EVHRD 50/25	518	252	100	2x160	▼
Verticale	EVHRD 30/15	347	177	100	1x160	▼
	EVHRD 50/25	518	252	100	2x160	▼

