

HIGH INDUCTION SWIRL DIFFUSER



Serie EDE2 (Square)- EDE2R (Circular)

High-induction swirl diffuser on squared panel (EDE2) or circular panel (EDE2R) dedicated to ceiling installation. Suitable both for cooling and heating in variable flow systems installations where a high number of air exchange per hour is required.

EDE diffusers allow a high induction ratio (mixing capacity) between supplied and ambient air. Panels have laser cut slits where adjustable aerodynamic profile deflectors are mounted.

Installation, regulation and maintenance are easily operated.

FEATURES:

- Material: galvanised steel panel with deflectors in polymeric material.
- Standard finishing: panel painted RAL 9016 and deflectors RAL 9005.
- Special finishing: panel painted according different RAL colour.
- Mounting: with lateral screws or central screw on plenum box mounting bridge.

The panel is made of steel sheet painted with epoxy resin-based powder, electrostatically laid and oven-dried. This type of painting is resistant to any impacts or abrasions and keeps its aesthetic characteristics unchanged over time.

The ABS deflectors are suitable for both heating & air conditioning temperatures; deflectors are adjustable and have possibility of launching horizontally, vertically or with a helical effect.

Installation with plenum box by lateral non-visible screws or by central screw fixed to the plenum box internal mounting bridge.

USE:

High-induction swirl diffuser suitable for installation in environment with high between 2,5 and 4 m both in cooling and heating conditions.

Deflectors can be adjusted also after diffuser installation to grant possibility of adjusting and optimise air flow direction in the room.

EDE diffusers can be supplied without deflectors in case of using only for return air.

The helical flow of the supplied air can be oriented clockwise, anti-clockwise or alternately simply by varying the position of the deflectors. The air flow direction is adjusted manually by acting on the deflectors which have a snap movement designed to ensure that deflectors position is maintained during airflow passage.

VARIANTS:

Available models:

- EDE2 Square diffuser with helical effect and deflectors arranged radially on a circular shape.
- EDE2R Circular diffuser with helical effect and deflectors arranged radially on a circular shape.

ACCESSORIES:

Insulated or non-insulated plenum box, equipped with regulation damper in spigot, equalizer and mounting bridge for installation by central screw and connection for lateral or upper flexible duct.

CODES:

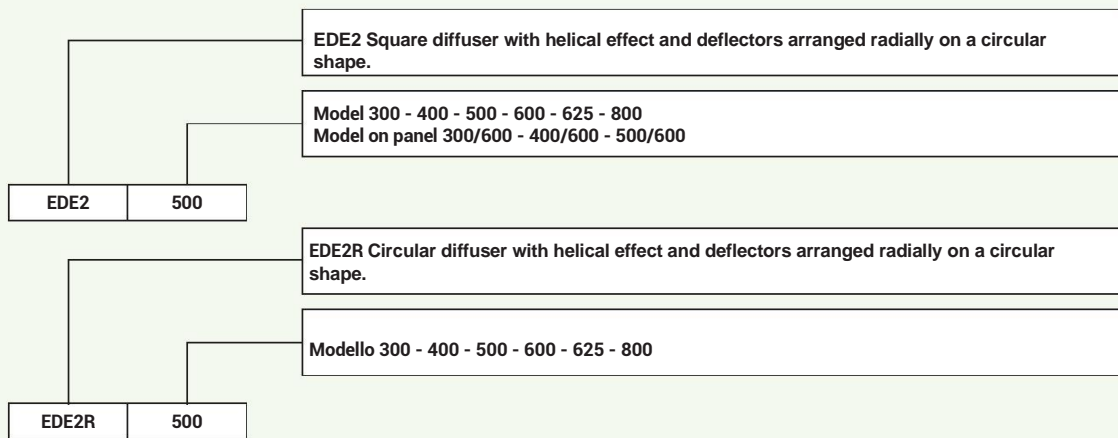

SQUARE PANEL DIMENSIONS:

Model EDE2	Dimensions	
	A	B
300	295	295
400	395	395
500	495	495
600	595	595
625	620	620
800	795	795

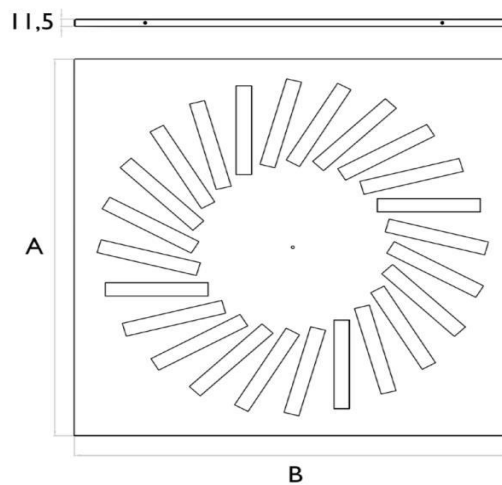

CIRCULAR PANEL DIMENSIONS:

Model EDE2R	Ø Nominal
	Ø A
300	296
400	396
500	496
600	596
625	621
800	796

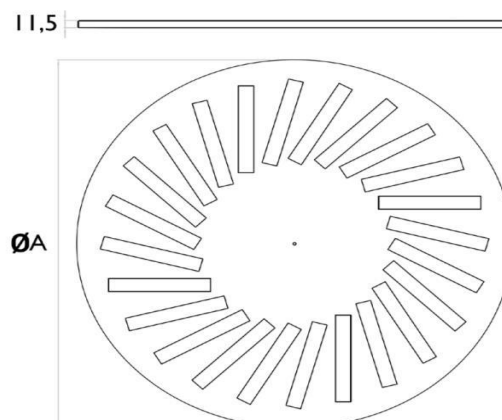

DEFLECTORS REGULATION:

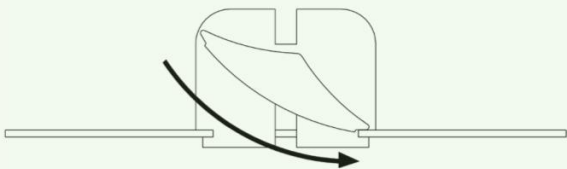

- Deflector position by maximal horizontal throw

Helical effect is obtained by tilting the deflectors. A clockwise or anti-clockwise vortex will be obtained depending on the tilting direction.

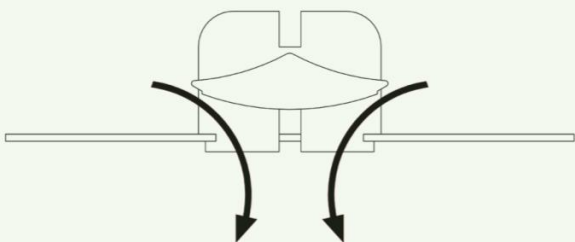

- Deflector position by maximal vertical throw

Vertical throw is obtained by keeping the deflectors straight; this solution is recommended in heating function to reach maximum airflow penetration into the room.

AIR THROW WITH DEFLECTORS TILTED ON THE RED SIZE:

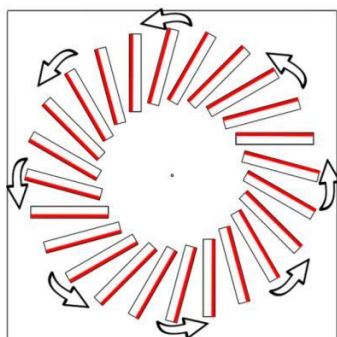

- Helicoidal Throw

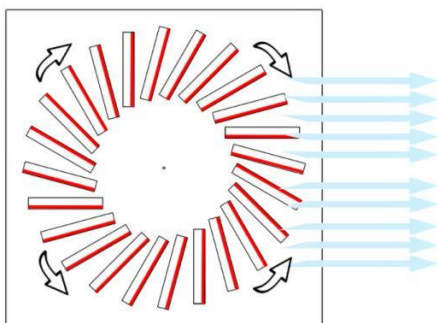

- Single Direction Throw

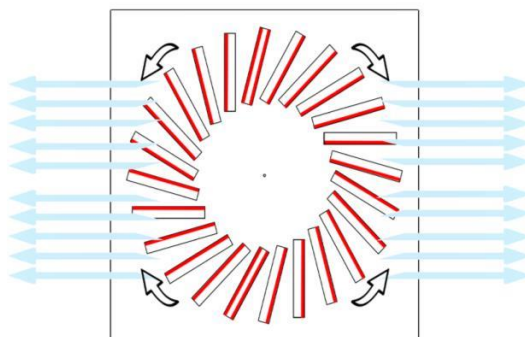

- Two Direction Throw

OPERATING DATA:

Model EDE2 EDE2R	Effective Section Ak m ²	Vk	2	3	4	5	6	Nr. deflectors
300	0,0092	Q	67	100	135	165	200	10
		Dp	5	11	20	32	47	
		L	0,9	1,3	1,7	2,2	2,9	
		dB(A)	20	25	30	35	40	
400	0,0161	Q	115	175	230	290	350	12
		Dp	2	5	9	16	24	
		L	1,1	1,6	2,1	2,7	3,2	
		dB(A)	20	25	30	35	40	
500	0,0253	Q	180	275	365	455	545	16
		Dp	2	6	11	19	30	
		L	1,3	2	2,7	3,4	4	
		dB(A)	20	25	30	35	40	
600	0,0380	Q	275	410	545	685	820	24
		Dp	3	7	13	23	35	
		L	1,7	2,5	3,2	4	5	
		dB(A)	20	25	30	35	40	
625	0,0380	Q	275	410	545	685	820	24
		Dp	3	7	13	23	35	
		L	1,7	2,5	3,2	4	5	
		dB(A)	20	25	30	35	40	
800	0,0668	Q	480	720	960	1200	1440	24
		Dp	3	9	18	30	47	
		L	2,1	3,2	4,4	5,5	6,5	
		dB(A)	20	25	30	35	40	

LEGEND:

- Ak [m²] Effective Section
- Vk [m/s] Effective Air Speed
- Q [m³/h]: Air volume
- Dp [Pa] Total Air Drop
- L [m] Throw: Max. airflow distance with terminal air speed 0,25 m/s.
- dB(A) Weighted sound power level.

CORRECTIVE FACTORS

Corrective multiplication factor for non-isothermal horizontal launch.

$\Delta T [^{\circ}C]$	K
-10	0,85
0	1
10	1,2

Corrective multiplication factor for non-isothermal vertical launch.

$\Delta T [^{\circ}C]$	K
-10	0,40
0	1
10	1,45

K: table shows the variation of constant K (constant to be multiplied by the non-isothermal horizontal launch) related to exit temperature variation +10 °C, 0 °C, -10 °C.

PLENUM BOX EDE 2:

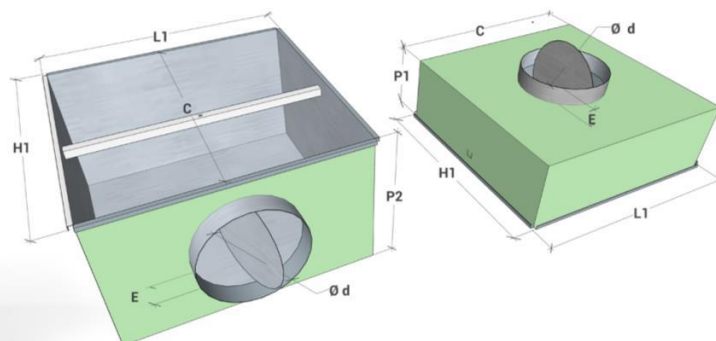

PLENUM BOX CONSTRUCTION:

- Material: Galvanised Steel.
- Available Models:
 1. Galvanised plenum box with damper in spigot and mounting bridge;
 2. Galvanised plenum box with damper in spigot and mounting bridge and equalizer;
 3. Galvanised insulated plenum box with damper in spigot and mounting bridge;
 4. Galvanised insulated plenum box with damper in spigot and mounting bridge and equalizer.

Plenum box Model	Compatible Diffuser	External Dimensions L1 x H1	Ø d	P1	P2	C	E
300	EDE2 300	292x292	146	200	250	260	50
	EDE2 300/600						
400	EDE2 400	392x392	198	200	300	360	50
	EDE2 400/600						
500	EDE2 500	492x492	198	200	300	460	50
	EDE2 500/600						
600	EDE2 600	592x592	248	200	350	560	50
	EDE2 300/600						
	EDE2 400/600						
	EDE2 500/600						
625	EDE2 625	617x617	248	200	350	585	50
800	EDE2 800	792x792	298	250	400	760	50

PLENUM BOX EDE2R:

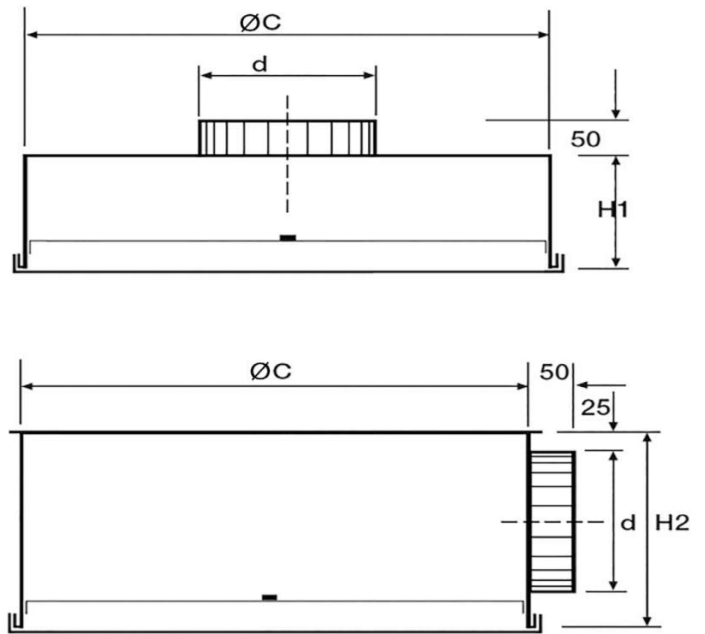
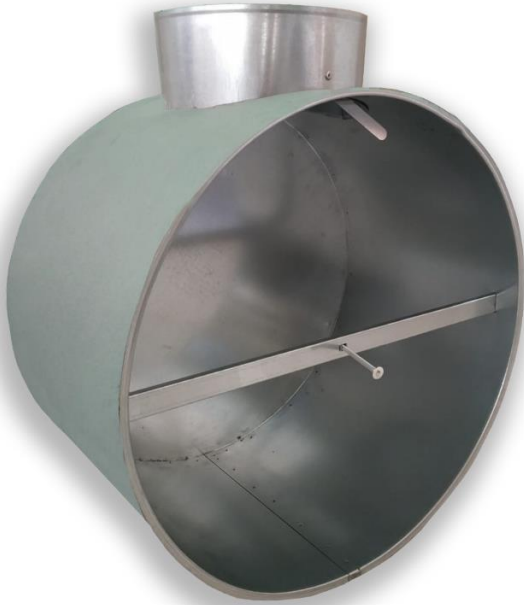

PLENUM BOX CONSTRUCTION:

- Material: Galvanised Steel.
- Available Models:
 1. Galvanised plenum box with damper in spigot and mounting bridge;
 2. Galvanised plenum box with damper in spigot, mounting bridge and equalizer;
 3. Galvanised insulated plenum box with damper in spigot and mounting bridge;
 4. Galvanised insulated plenum box with damper in spigot, mounting bridge and equalizer.

Model EDE2R	Dimensions EDE2R (mm)	Plenum Box Dimensions (mm)			
	\varnothing Nominal	$\varnothing d$	H1	H2	$\varnothing C$
300	296	146	200	250	260
400	396	198	200	300	360
500	496	198	200	300	460
600	596	248	200	350	560
625	621	248	200	350	585
800	796	298	250	400	760

MOUNTING WITH PLENUM BOX ON A PLASTERBOARD FALSE CEILING

- Hang the plenum box from the ceiling using special brackets or chains fixed to the plenum box whose external edge can be drilled;
- Insert the flexible duct onto the connection sleeve, securing it with the appropriate hose clamp;
- Mount the diffuser either using the central screw, screwing it onto the fixing bridge of the plenum or n. 4 self- drilling side screws.

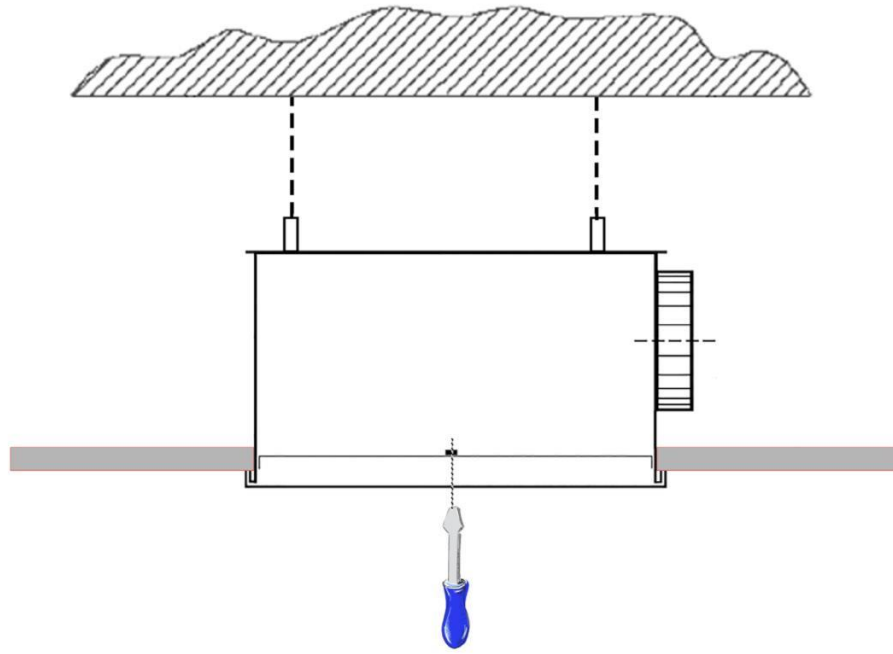

MOUNTING ON THE SQUARE FALSE CEILING

- Hang the plenum box from the ceiling using special brackets or chains fixed to the plenum whose external edge can be drilled;
- Insert the flexible conduit onto the connection sleeve, securing it with the appropriate hose clamp;
- Mount the diffuser either using the central screw by screwing it onto the plenum fixing bridge or through the n. 4 self-drilling side screws;
- Place the diffuser already fixed on the plenum box on the appropriate square space of the false ceiling.

